

**Features**

- N Channel, enhancement mode
- Avalanche characteristic
- Short connections and built-in gate resistors to suppress internal oscillations even in critical applications
- Isolated copper baseplate
- All electrical connections on top for easy busbaring Large clearances (10mm) and creepage distances (20mm)



**Typical Applications**

- Switched mode power supplies
- DC servo and robot drives
- DC choppers
- UPS equipment
- Not suitable for linear amplification

**Absolute Maximum Ratings**

(Tc=25°C, unless otherwise specified)

Symbol	Conditions	Values	Units
V <sub>DS</sub>	T <sub>s</sub> =25(80)°C 1ms	100	V
I <sub>D</sub>		100(150)	A
I <sub>DM</sub>		600	A
V <sub>GS</sub>		±2	V
T <sub>vj</sub> , (T <sub>stg</sub> )		-40...+150(125)	°C
V <sub>isol</sub>	AC, 1min.	2500	V
<b>Inverse diode</b>			
I <sub>F</sub> = -I <sub>S</sub>		200	A
I <sub>FM</sub> = -I <sub>SM</sub>		600	A

**Characteristics**

(Tc=25°C, unless otherwise specified)

Symbol	Conditions	min.	typ.	max.	Units	
V <sub>(BR)DSS</sub>	V <sub>GS</sub> = 0V, I <sub>D</sub> = 0.25mA	100			V	
V <sub>GS(th)</sub>	V <sub>GS</sub> = V <sub>DS</sub> , I <sub>D</sub> = 1mA	2.1	3	4	V	
I <sub>DSS</sub>	V <sub>GS</sub> = 0V V <sub>DS</sub> = 100V, T <sub>j</sub> = 25(125)°C		50(300)	250(1000)	µA	
I <sub>GSS</sub>	V <sub>GS</sub> = 20V V <sub>DS</sub> = 0V		10	100	nA	
R <sub>DS(on)</sub>	V <sub>GS</sub> = 10V I <sub>D</sub> = 130A		7	8.5	mΩ	
g <sub>fs</sub>	V <sub>DS</sub> = 25V I <sub>D</sub> = 130A	60	75		S	
C <sub>CHC</sub>	V <sub>GS</sub> = 0V, V <sub>DS</sub> = 25V, f = 1 MHz			160	pF	
C <sub>iss</sub>			10	13	nF	
C <sub>oss</sub>				5	7.5	nF
C <sub>rss</sub>				1.8	2.7	nF
L <sub>DS</sub>					20	nH
t <sub>d(on)</sub>	V <sub>DD</sub> = 50V I <sub>D</sub> = 130A			60	ns	
t <sub>r</sub>	V <sub>GS</sub> = 10V R <sub>G</sub> = 3.3Ω			220	ns	
t <sub>d(off)</sub>				270	ns	
t <sub>f</sub>				200	ns	

**Characteristics**

(Tc=25°C, unless otherwise specified)

Symbol	Conditions	min.	typ.	max.	Units
<b>Inverse diode</b>					
$V_{SD}$	$I_F=400A; V_{GS}=0V$		1.25	1.6	V
$t_{rr}$	$T_j=25(150)^\circ C$		400		ns
$Q_{rr}$	$T_j=25^\circ C$		3.5		$\mu C$
$I_{rr}$	$T_j=150^\circ C$				A
<b>Thermal characteristics</b>					
$R_{th(j-c)}$	per MOSFET			0.18	K/W
$R_{th(c-s)}$	Ms' surface 10 $\mu m$ ,per module			0.05	K/W
<b>Mechanical data</b>					
$M_s$	to heatsink (M6)	4		5	Nm
$M_t$	for terminals (M5)	2.5		3.5	Nm
W				130	g

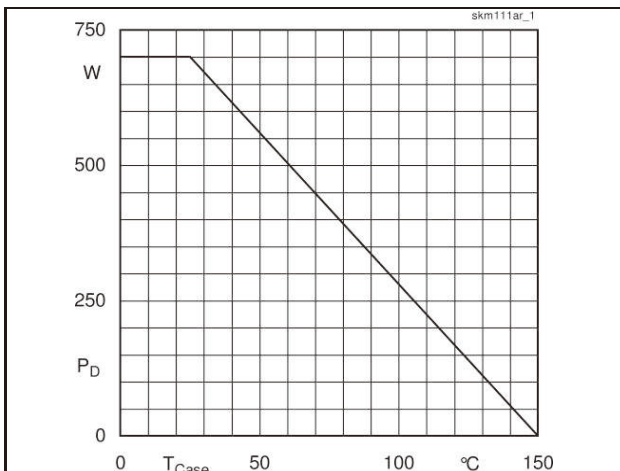

Fig. 1 Rated power dissipation vs. temperature

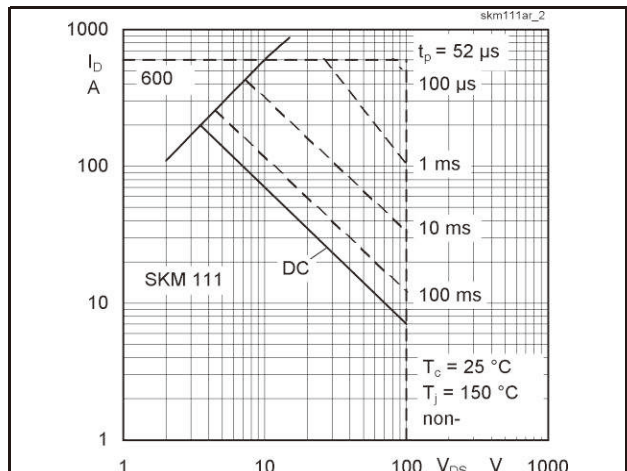

Fig. 2 Maximum safe operating area

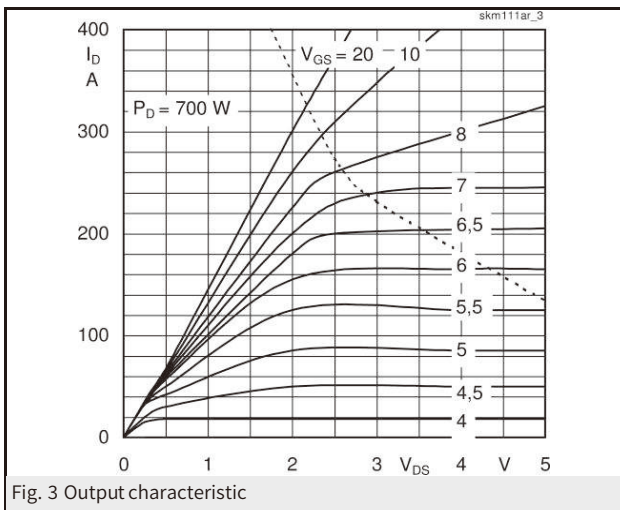

Fig. 3 Output characteristic

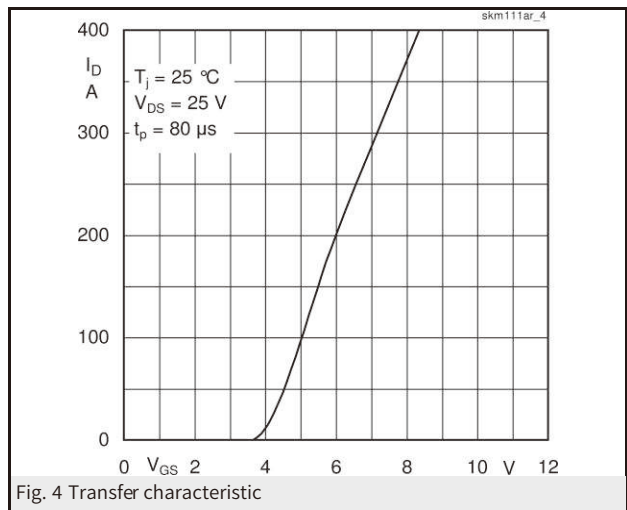
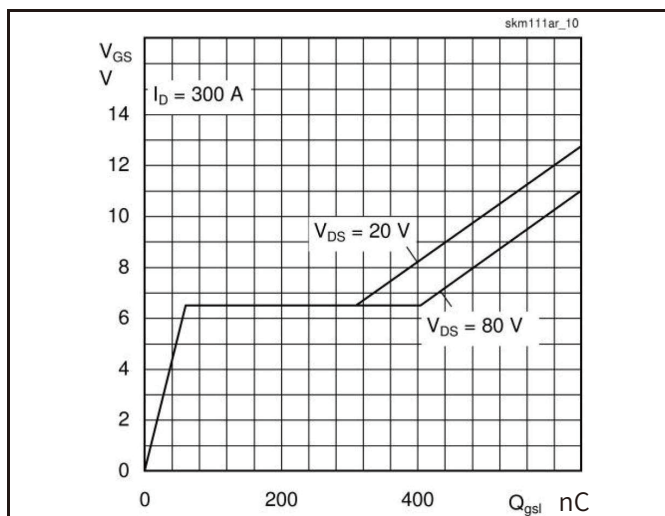
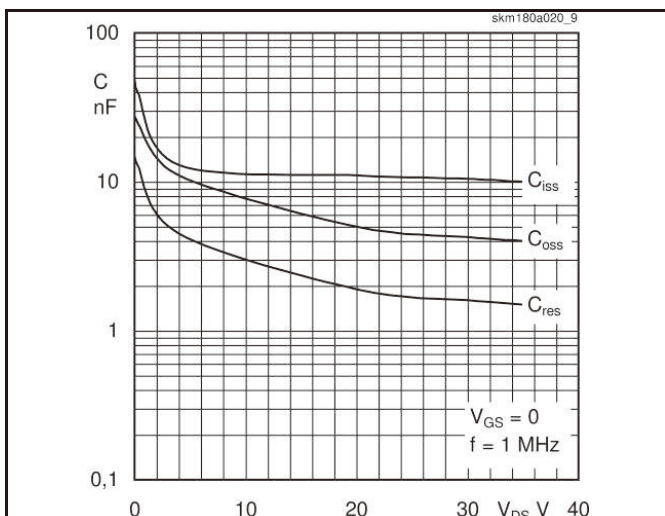
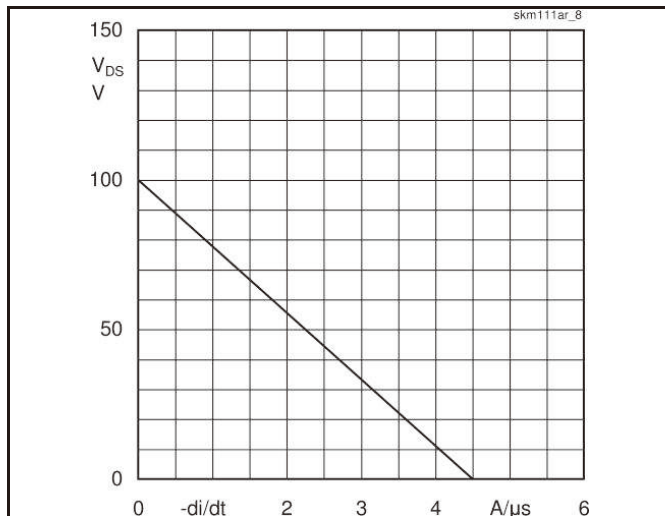
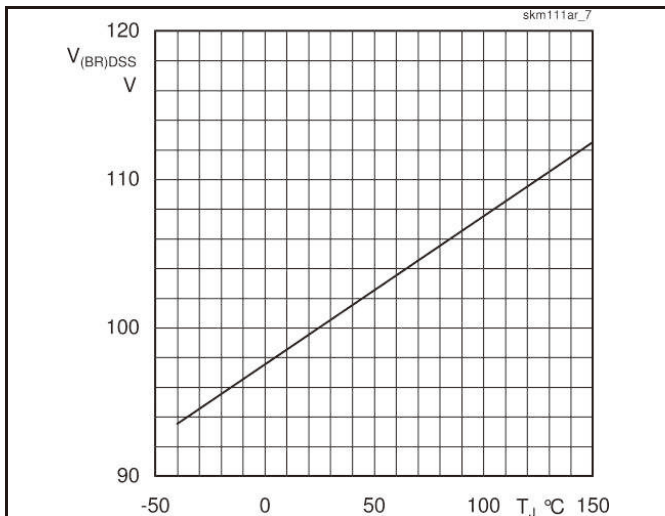
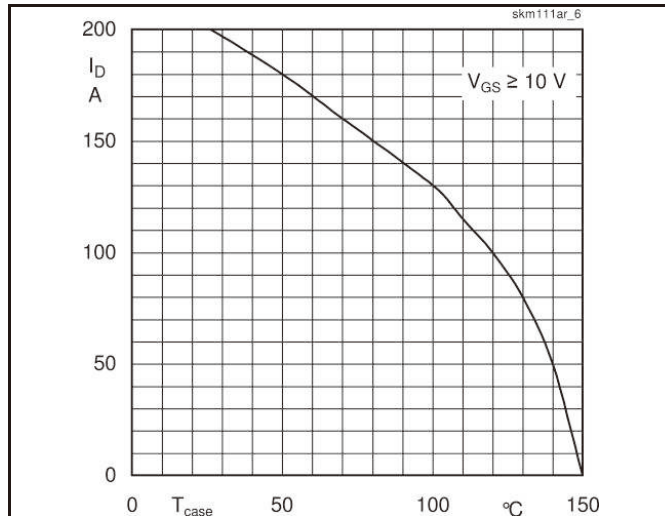
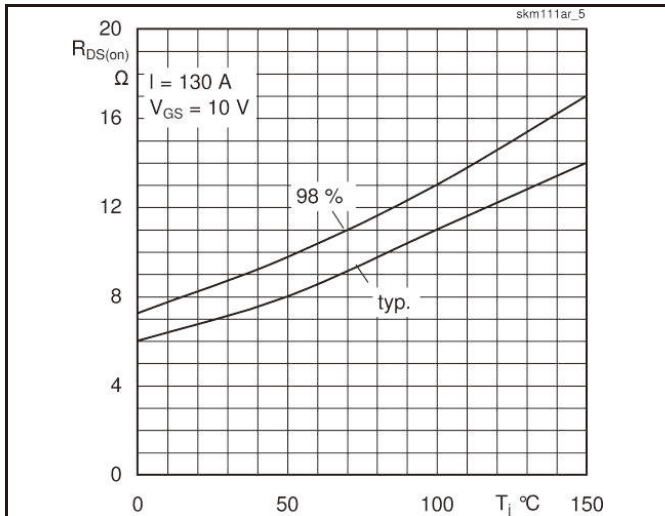

Fig. 4 Transfer characteristic



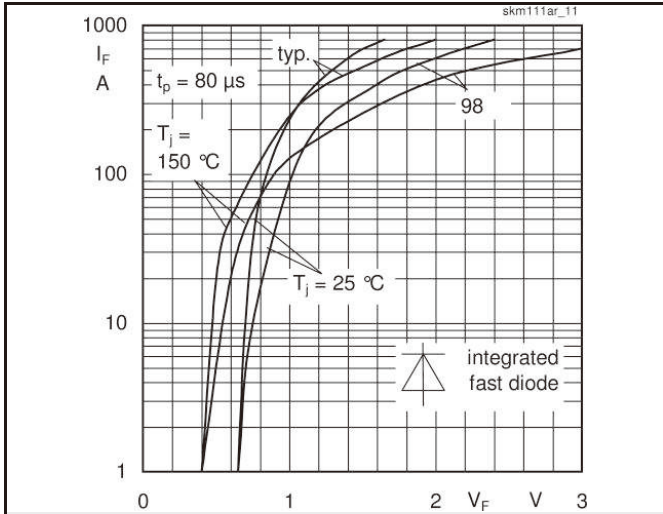

Fig. 11 Diode forward characteristic

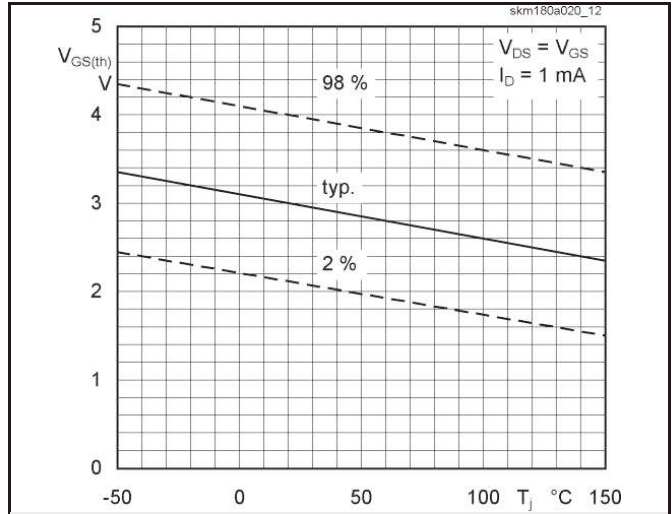
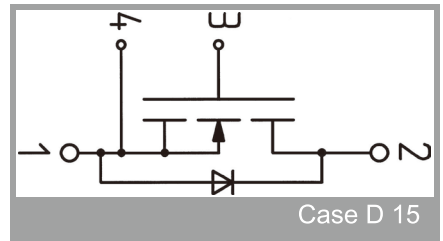
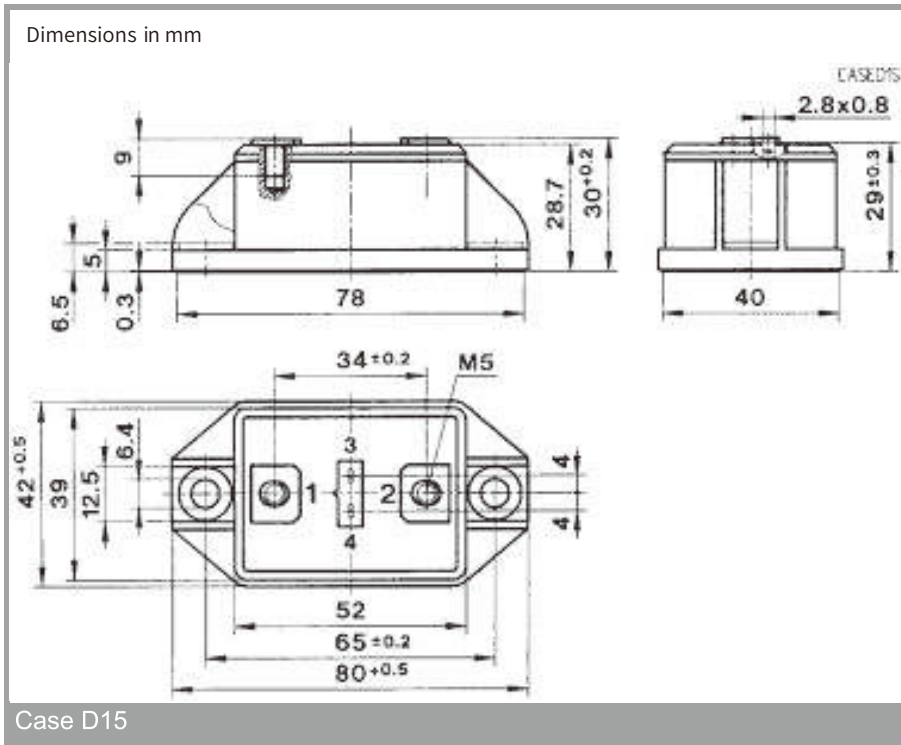

Fig. 14 Gate-source threshold voltage



Case D 15

This is an electrostatic discharge sensitive device (ESDS), international standard IEC 60747-1, chapter IX.