

General

GVC313-630/1140 series AC vacuum contactor is used in an AC. 50-60 Hz electric power system, with rated working voltage of 1140V, and rated current of 630A, for direct or remote on-off control of the main circuit, circuit-breaking control and frequently control of the motor. It can become electromagnetic starter, on the basis of combining with various kinds of protecting device and can also become anti-exploding magnetic starter. This series adopts before- and-after layout between the main circuit and controlling circuit, and adopts electric maintaining structure, and vacuum interrupter with ceramic shell.

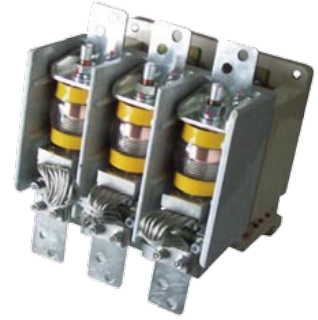

Type and specification of the product

G VC 313 - 630A / 1140V

1 2 3 4 5

1. GREEGOO
2. Vacuum Contactor
3. Design sequence no.
4. Rated working current (A)
5. Rated working voltage (V)

Normal working conditions

- **Applicable Elevation:** the elevation of the installation place should be less than 2000m.
- **Ambient temperature:** -5°C~+40°C.
- **Relative humidity:** maximum monthly averaged relative humidity is 90% when the highest averaged air temperature is +25°C in most humid months. Having taken into account the condensation dew on the surface of the product due to the temperature variation.
- **Working conditions:** the places where are without strong sunshine, rain and snow, without explosive danger and gas or dust to damage the metal and insulation, without strongly vibrated/shocked and collided.
- **Contamination class:** class III.

Structure and working principle

The vacuum contactor mainly consist of vacuum switch tube, base, rotating arm of force, electro-magnetic coil, opening spring, contact spring, spacing part and so forth. (See Fig.1) when the electro-magnetic coil gets power, attract the moving armature to drive the rotating arm of force do anticlockwise rotation. The rotating arm of force, by way of contact spring, press the moving contact and fixed contact in the vacuum switch tube to touch, then the main circuit will make. After the power to the electro-magnetic coil cut off, the moving armature, by the effect of opening spring, drives the rotating arm of force to do clockwise rotation. After the overtravel H, the rotating arm of force drives the moving contact rod to press the moving contact and fixed contact separate, then the main circuit will cut off. Because of the spacing component, the rotation angle of the rotating arm of force if fixed and never change.

The vacuum switch tube consists of moving/fixed contact, bellow, conducting rod, ceramic enclosure and so forth. (see Fig.1) the bellow can make sure the separation between the vacuum in tube and outside air when the contact do axial motion and ensure the moving/fixed contact in the vacuum condition.

Main technical data

Technical data	Data	Unit
Rated voltage of main circuit	1140	V
Rated current of main circuit	630	A
Making capacity of main circuit	3.6/50	kA/time
Breaking capacity of main circuit	5/50	kA/time
Limit breaking capacity	6.3/3	kA/time
Electrical life AC3	60	10000 time
Electrical life AC4	6	10000 time
Mechanical life	300	10000 time
Rated operating frequency AC3	600	Time/hour
Rated operating frequency AC4	120	Time/hour
Short time operating frequency 20s	2000	Time/hour
Pole number of main circuit	3	pole
Pressure of main contact	150	N
Stroke of contact	2±0.5	Mm
Overtravel	1±0.5	Mm
Contact resistance of main circuit	≤150	μΩ
Control circuit voltage	220, 230, 380	V
Attracting power of control circuit	<900	VA
Holding power of control circuit	<50	VA
Outline dimension	270×300×260	Mm
Installation dimension	240×224	Mm
Weight		kg

Remark: working voltage of control circuit can be made according to the requirement of the customer.

Installation and operation

>> Installation

■ The contactor shall be installed as in the normal operation position. The contactor must be installed on a level plane and the slope shall not be larger than 15°. We suggest the moving terminal of vacuum switch tube is down towards when installation.

■ Connect the wires correctly. The control power supply voltage should be in compliance with the control voltage of the contactor.

Installation and operation

>> Operation

■ During the operation, the vacuum switch tube of the contactor should be checked every half year (by way of power frequency withstand voltage), the withstand voltage should be higher than 6KV, otherwise it should be replaced. We suggest using the 5KV or 2.5KV insulation resistance shaking device to check, it should be monitored when the insulation resistance of vacuum switch tube is lower than 100MΩ, and should be replaced if lower than 20 MΩ. Please pay attention whether the out ceramic surface of the vacuum switch tube is humid or other reason causes the insulation lower to avoid making wrong conclusion.

■ During the operation, keep the contactor in clean, periodically adjust its stroke and overtravel (one time per 3 months), and check its structural elements for loosened connections.

■ Check method of stroke: (see Fig.1) measure the L value by vernier calipers, the difference of the value measured at opening and that at the closing is the stroke. The stroke value should be in compliance with that in table 1.

■ Measure method of overtravel: (see Fig.1) under the state of closing, measure the H value by vernier calipers or other special measurement tool. The overtravel value should be in compliance with that in table 1. The contactor must not be operated under the condition of without overtravel. Attention: the adjustment of contactor must use the special measurement instrument such as synchro tester, open/close speed tester. We do not agree the customer adjust and repair the contactor by way of eyesight and feel. Otherwise the characteristics of the contactor will be reduced and cause the unexpected damage..

Transportation & Storage

- During the transportation process the contactor should not be converted, turned over, strongly vibrated/shocked and collided.
- During the transportation and storage process of the contactor, it cannot suffer the invasion of rain and snow. It should be stored in the warehouse without the invasion of rain and snow, with circulating air, and relative humidity of air not exceeding 85%, and air temperature not higher than +40°C and not lower than -25°C.

Unpack & Inspection

- Inspect the package for its completeness, and check it for damage.
- Check the contactor if comply with the purchase order, and check the spare parts and attached document if comply with the packing list.
- Make corresponding inspection to the contactor.

Notice when placing the order

Please state the following when placing the order:

- Title, model/specification of the product;
- Rated voltage, rated current and rated control voltage;
- Quantity of product and spare parts;
- Other special requirements.

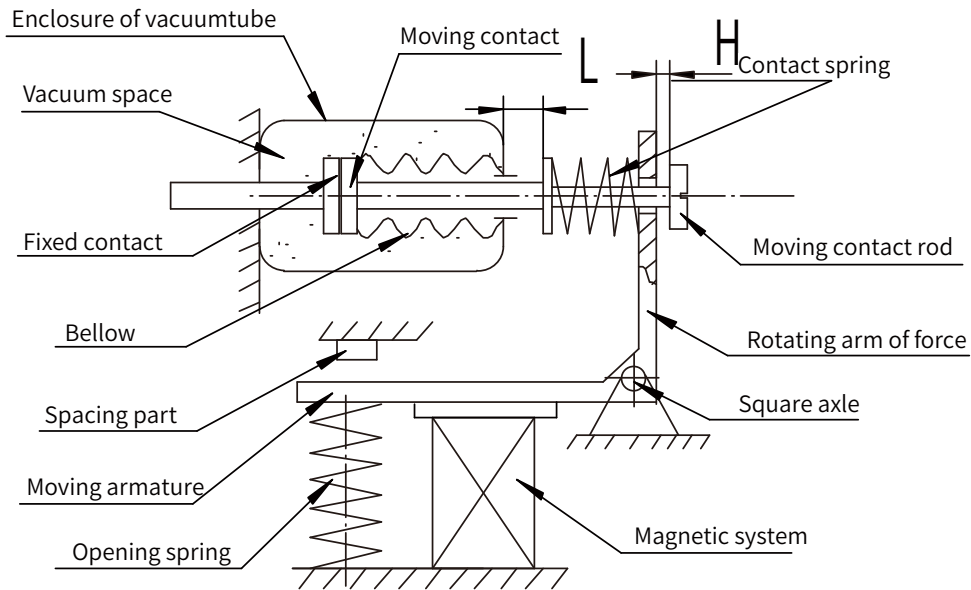

(Fig. 1) working principle drawing of contactor

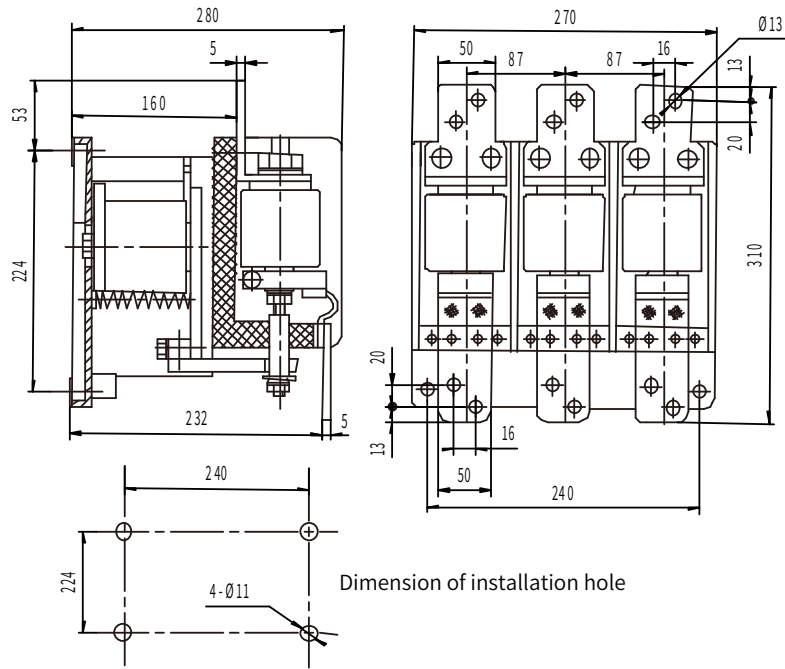
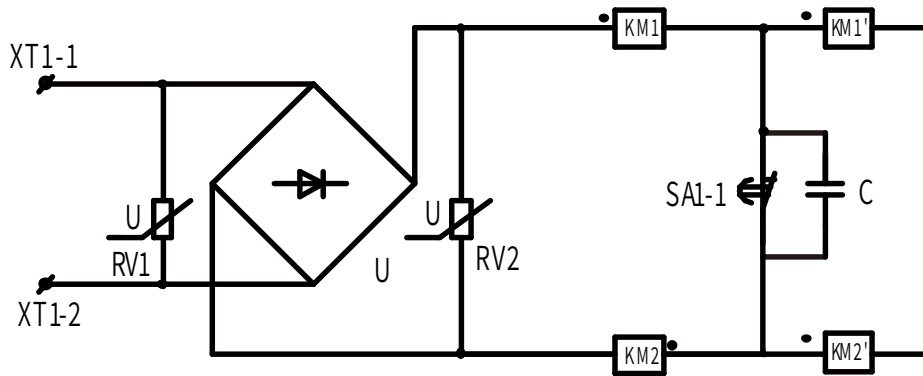
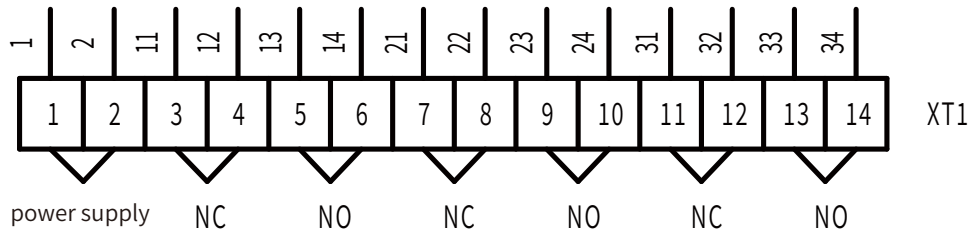

Fig. GVC313-630A/1140V dimension and install hole drawing



U: rectifier bridge; SA: auxiliary switch; RV: varistor; C: capacitor; KM+KM':coil
GVC313-630A/1.14KV AC vacuum contactor scheme



GVC313-630A/1.14KV wiring terminal diagram